

★ SOUND CONTROL SYSTEMS ON INTERIOR FLOORS

DETAIL- A THIN SYSTEM OVER PLYWOOD

331F-SC-2009/2010

SUITABLE SUBSTRATES

- Provide a suitable rigid subfloor that is designed to support the maximum loading anticipated for the area to be tiled. Floor systems, including the framing system and subfloor panels, over which the tile will be installed shall be in conformance with the Canadian National Building Code 2005 and applicable local building codes taking into consideration anticipated live and dead loads.

MATERIALS

- SOUND REDUCTION MEMBRANE
2000SC Flexilastic Sound Control & Crack Isolation Membrane with 4000 or 4001 Flexilastic Primer (ANSI 118.12)
– meets new ANSI A118.XX* standard for Bonded Sound Reduction Membranes for Thin-set Ceramic Tile and Dimension Stone Installation.
This standard applies to trowel applied, liquid and flexible sheet membranes.
- BOND COAT:
Flextile 50, 52, 56SR, 61, 62 or 66 Polymer Modified Mortars (ANSI A118.4/A118.11)
Flextile 51 / 44 – two component Latex Mortar System (ANSI A118.4/A118.11)
Flextile 58XT Fast Set two-component Latex Mortar System (ANSI A118.4/A118.11)
- GROUT
Flextile Polymer Modified Grout (ANSI A118.7)
ColourMax Plus Urethane Grout
Flexepoxy 100 – 100 % Solid Epoxy Grout (ANSI A118.3)
- GYPSUM BOARD – ASTM C36 Type X 15 mm thick
- RESILIENT CHANNELS – 1 or 2 legged
- SOUND ABSORBANT BATT – Fiberglass batt, natural cotton fiber or other.
- ACOUSTICAL SEALANT- ASTM C919-08

APPLICATION

- Apply sound reduction membrane following manufacturer's recommendations to provide complete coverage of the substrate in the area on which the tile is to be installed. Install tile in accordance with ANSI A 108.5 Use sufficient bond-coat to ensure a minimum 95% contact.
 - All perimeters must be recessed away from the walls and acoustic sealant or prefabricated movement joints must be applied Slide tile firmly into position while bond coat is wet and tacky. Force grout into full depth of tile joint.
- Remove excess grout and clean.

LIMITATIONS

- Some systems may require epoxy grout and/or epoxy bond-coat.
- Some products/systems cannot be used in commercial applications where heavy loads and carts will be used.
A "Light Commercial" to "Heavy Commercial" rating utilizing ASTM C-627-99 should be required.

OTHER CONSIDERATIONS

- Sound reduction membranes are intended to minimize the transfer of sound from one room to the room below, it is however only part of the overall system. Substrates, flooring material, dropped ceiling assemblies, perimeter joints, etc, will all affect the overall values.
- Movement Joint (architect must specify type of joint and show location and details on drawings)
- Movement joints - mandatory according to Detail 301MJ-2009/2010.
- All systems must meet or exceed a "Residential Rating" with ASTM C-627-99
- Some systems require 2 layers of 15 mm type X Gypsum Ceiling
- Refer to notes on "Sound Control Underlayment" Boards
- Ratings may vary from **46 IIC to approximately 54 IIC** using ASTM E-492 depending on product and other components in the system.
- This floor assembly has little or no effect on STC rating, normally this floor assembly will have an STC of 50 or more, when the appropriate sound rated wall detail is used.

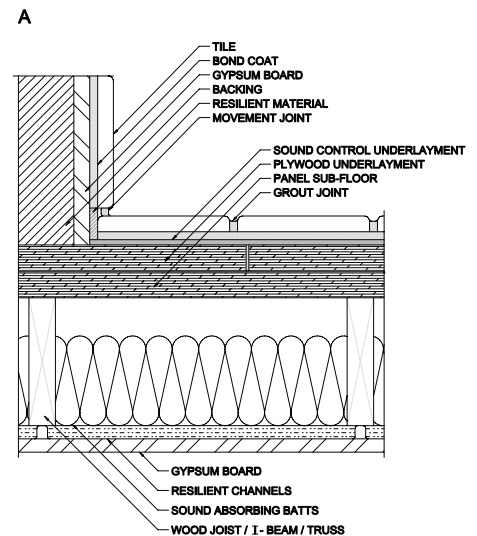

The above installation detail is used with the permission of the Terrazzo Tile & Marble Association of Canada. The installation products shown are Flexile's product recommendations for this specific detail, and are not intended to replace TTMAC's original generic specification.

331F-SC SOUND CONTROL SYSTEMS ON INTERIOR FLOORS

DETAIL- B THICK SYSTEM OVER PLYWOOD

SUITABLE SUBSTRATES

- Provide a suitable rigid subfloor that is designed to support the maximum loading anticipated for the area to be tiled. Floor systems, including the framing system and subfloor panels, over which the tile will be installed shall be in conformance with the Canadian National Building Code 2005 and applicable local building codes taking into consideration anticipated live and dead loads.

MATERIALS

- SOUND REDUCTION MEMBRANE
2000SC Flexilastic Sound Control & Crack Isolation Membrane with 4000 or 4001 Flexilastic Primer (ANSI 118.12)
- BOND COAT:
Flextile 50, 52, 56SR, 61, 62 or 66 Polymer Modified Mortars (ANSI A118.4)
Flextile 51 / 44 – two component Latex Mortar System (ANSI A118.4/A118.11)
Flextile 58XT Fast Set two-component Latex Mortar System (ANSI A118.4/A118.11)
- GROUT
Flextile Polymer Modified Grout (ANSI A118.7)
ColourMax Plus Urethane Grout
Flexepoxy 100 – 100 % Solid Epoxy Grout (ANSI A118.3)
- GYPSUM BOARD – ASTM C36 Type X 15 mm thick
- RESILIENT CHANNELS – 1 or 2 legged
- SOUND ABSORBANT BATT – Fiberglass batt, natural cotton fiber or other.
- ACOUSTICAL SEALANT- ASTM C919-08

APPLICATION

- Apply sound reduction membrane following manufacturer's recommendations to provide complete coverage of the substrate.
- Apply mortar bed (see Tile Guide Specification Section Mixes 2.5.5) to required thickness over fresh slurry bond coat (see Tile Guide Specification Section Mixes 2.5.2). Finished tolerance of mortar bed not to exceed 6 mm in 3049 mm or 2 mm in 305 mm.
- Install tile in accordance with ANSI A 108.5 Use sufficient bond-coat to ensure a minimum 95% contact.
- All perimeters must be recessed away from the walls and acoustic sealant or prefabricated movement joints must be applied. Slide tile firmly into position while bond coat is wet and tacky. Force grout into full depth of tile joint. Remove excess grout and clean.

LIMITATIONS

- Some products/systems cannot be used in commercial applications where heavy loads and carts will be used. A "Light Commercial" to "Heavy Commercial" rating utilizing ASTM C-627-99 should be required.
- This assembly will normally raise the floor from anywhere from 30 mm to 62.5 mm in height. Height restrictions should be evaluated.

OTHER CONSIDERATIONS

- Sound reduction membranes are intended to minimize the transfer of sound from one room to the room below, it is however only part of the overall system. Substrates, flooring material, dropped ceiling assemblies, perimeter joints, etc, will all affect the overall values.
- Movement Joint (architect must specify type of joint and show location and details on drawings)
- Movement joints - mandatory according to Detail 301MJ-2009/2010.
- All systems must meet or exceed a "Residential Rating" with ASTM C-627-99
- Some systems require 2 layers of 15 mm type X Gypsum Ceiling
- Refer to notes on "Sound Control Underlayment"
- Ratings may vary from **48 IIC to approximately 58 IIC** using ASTM E-492 depending on product and other components in the system. This floor assembly has little or no effect on STC rating, normally this floor assembly will have an STC of 50 or more, when the appropriate sound rated wall detail is used.
- Detail 314F-C2 Modular Screed System Over Plywood can be used as alternative to a monolithic mortar bed

B

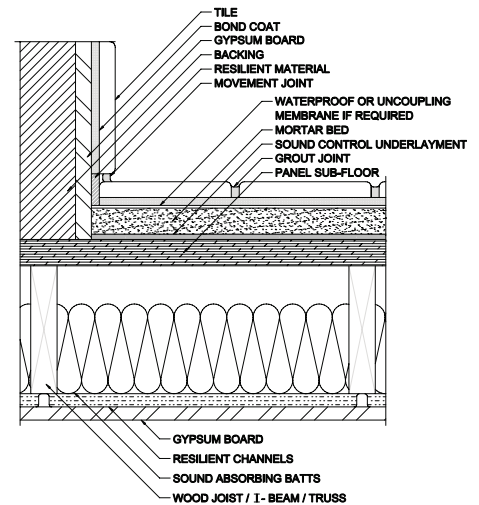

331F-SC SOUND CONTROL SYSTEMS ON INTERIOR FLOORS

DETAIL - C THIN SYSTEM ON CONCRETE WITH DROPPED CEILING

SUITABLE SUBSTRATES

MATERIALS

- SOUND REDUCTION MEMBRANE
2000SC Flexilastic Sound Control & Crack Isolation Membrane with 4000 or 4001 Flexilastic Primer (ANSI 118.12)
- BOND COAT:
Flextile 50, 52, 56SR, 61, 62 or 66 Polymer Modified Mortars (ANSI A118.4)
Flextile 51 / 44 – two component Latex Mortar System (ANSI A118.4/A118.11)
Flextile 58XT Fast Set two-component Latex Mortar System (ANSI A118.4/A118.11)
Flexepoxy 100 – 100 % Solid Epoxy Mortar (ANSI A118.3).
- GROUT
Flextile Polymer Modified Grout (ANSI A118.7)
ColourMax Plus Urethane Grout
Flexepoxy 100 – 100 % Solid Epoxy Grout (ANSI A118.3).
- GYPSUM BOARD – ASTM C36 Type X 15 mm thick
- RESILIENT CHANNELS – 1 or 2 legged
- SOUND ASORBANT BATT – Fiberglass batt, natural cotton fiber or other.
- ACOUSTICAL SEALANT- ASTM C919-08

APPLICATION

- Apply sound reduction membrane following manufacturer’s recommendations to provide complete coverage of the substrate in the area on which the tile is to be installed. Install tile in accordance with ANSI A 108.5 Use sufficient bond-coat to ensure a minimum 95% contact.
- All perimeters must be recessed away from the walls and acoustic sealant or prefabricated movement joints must be applied Slide tile firmly into position while bond coat is wet and tacky. Force grout into full depth of tile joint. Remove excess grout and clean.

LIMITATIONS

- Some systems may require epoxy grout and/or epoxy bond-coat.
- Some products/systems cannot be used in commercial applications where heavy loads and carts will be used. A “Light Commercial” to “Heavy Commercial” rating utilizing ASTM C-627-99 should be required.

OTHER CONSIDERATIONS

- Sound reduction membranes are intended to minimize the transfer of sound from one room to the room below, it is however only part of the overall system. Substrates, flooring material, dropped ceiling assemblies, perimeter joints, etc, will all affect the overall values.
- Movement Joint (architect must specify type of joint and show location and details on drawings)
- Movement joints - mandatory according to Detail 301MJ- 2009/2010.
- All systems must meet or exceed a “Residential Rating” with ASTM C-627-99
- Some systems require 2 layers of 15 mm type X Gypsum Ceiling
- Refer to notes on “Sound Control Underlayment” Boards
- Ratings may vary from **54 IIC to approximately 68 IIC** using ASTM E-492 depending on product and other components in the system.
- This floor assembly has little or no effect on STC rating, normally this floor assembly will have an STC of 50 or more, when the appropriate sound rated wall detail is used.
- Request for test results for ASTM E-2179-03 from manufacturer to determine contribution on a concrete slab.
Product specified should have a contribution (Δ) IIC rating of 10 or greater

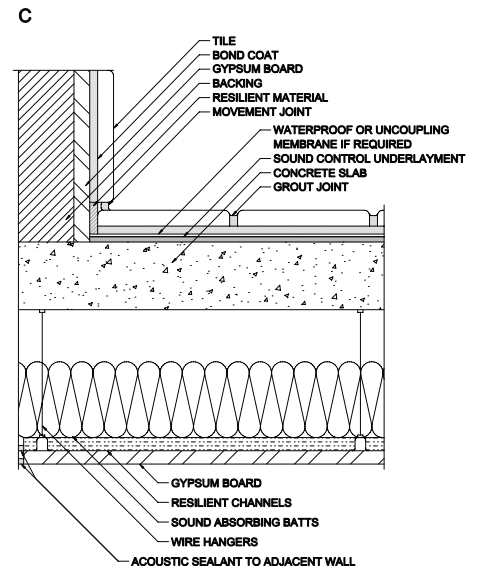

The above installation detail is used with the permission of the Terrazzo Tile & Marble Association of Canada. The installation products shown are Flextile’s product recommendations for this specific detail, and are not intended to replace TTMAC’s original generic specification.

331F-SC SOUND CONTROL SYSTEMS ON INTERIOR FLOORS

DETAIL - D THICK SYSTEM ON CONCRETE WITH DROPPED CEILING

SUITABLE SUBSTRATES

- Interior concrete slabs. Floor systems over which the tile is installed shall be in conformance with the Canadian National Building Code 2005 and applicable local building codes taking into consideration anticipated live and dead loads.

MATERIALS

- SOUND REDUCTION MEMBRANE
2000SC Flexilastic Sound Control & Crack Isolation Membrane with 4000 or 4001 Flexilastic Primer (ANSI 118.12)
- BOND COAT:
Flextile 50, 52, 56SR, 61, 62 or 66 Polymer Modified Mortars (ANSI A118.4)
Flextile 51 / 44 – two component Latex Mortar System (ANSI A118.4/A118.11)
Flextile 58XT Fast Set two-component Latex Mortar System (ANSI A118.4/A118.11)
Flexepoxy 100 – 100 % Solid Epoxy Mortar (ANSI A118.3)
- GROUT
Flextile Polymer Modified Grout (ANSI A118.7)
ColourMax Plus Urethane Grout
Flexepoxy 100 – 100 % Solid Epoxy Grout (ANSI A118.3)
- GYPSON BOARD – ASTM C36 Type X 15 mm thick
- RESILIENT CHANNELS – 1 or 2 legged
- SOUND ABSORBANT BATT – Fiberglass batt, natural cotton fiber or other.
- ACOUSTICAL SEALANT- ASTM C919-08

APPLICATION

- Apply sound reduction membrane following manufacturer's recommendations to provide complete coverage of the substrate.
- Apply mortar bed (see Tile Guide Specification Section Mixes 2.5.5) to required thickness over fresh slurry bond coat (see Tile Guide Specification Section Mixes 2.5.2). Finished tolerance of mortar bed not to exceed 6 mm in 3049 mm or 2 mm in 305 mm
- Install tile in accordance with ANSI A 108.5 Use sufficient bond-coat to ensure a minimum 95% contact.
- All perimeters must be recessed away from the walls and acoustic sealant or prefabricated movement joints must be applied Slide tile firmly into position while bond coat is wet and tacky. Force grout into full depth of tile joint. Remove excess grout and clean.

LIMITATIONS

- Some products/systems cannot be used in commercial applications where heavy loads and carts will be used. A "Light Commercial" to "Heavy Commercial" rating utilizing ASTM C-627-99 should be required.
- This assembly will normally raise the floor from anywhere from 30 mm to 62.5 mm in height. Height restrictions.

OTHER CONSIDERATIONS

- Sound reduction membranes are intended to minimize the transfer of sound from one room to the room below, it is however only part of the overall system. Substrates, flooring material, dropped ceiling assemblies, perimeter joints, etc, will all affect the overall values.
- Movement Joint (architect must specify type of joint and show location and details on drawings)
- Movement joints - mandatory according to Detail 301MJ- 2009/2010.
- All systems must meet or exceed a "Residential Rating" with ASTM C-627-99
- Some systems require 2 layers of 15 mm type X Gypsum Ceiling
- Refer to notes on "Sound Control Underlayment" Boards
- Ratings may vary from **65 IIC to approximately 70 IIC** using ASTM E-492
- This floor assembly has little or no effect on STC rating, normally this floor assembly will have an STC of 50 or more, when the appropriate sound rated wall detail is used.
- Request for test results for ASTM E-2179-03 from manufacturer to determine contribution on a concrete slab.
Product specified should have a contribution (Δ) IIC rating of 10 or greater
- Detail 314F-G Modular Screed System on concrete can be used as alternative to a monolithic mortar bed

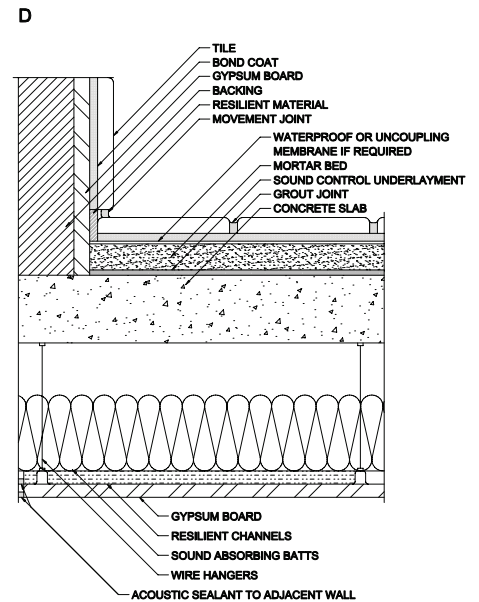

331F-SC SOUND CONTROL SYSTEMS ON INTERIOR FLOORS

DETAIL - E THIN SYSTEM ON CONCRETE NO DROPPED CEILING

SUITABLE SUBSTRATES

MATERIALS

- SOUND REDUCTION MEMBRANE
2000SC Flexilastic Sound Control & Crack Isolation Membrane with 4000 or 4001 Flexilastic Primer (ANSI 118.12)
- BOND COAT:
Flextile 50, 52, 56SR, 61, 62 or 66 Polymer Modified Mortars (ANSI A118.4)
Flextile 51 / 44 – two component Latex Mortar System (ANSI A118.4/A118.11)
Flextile 58XT Fast Set two-component Latex Mortar System (ANSI A118.4/A118.11)
Flexepoxy 100 – 100 % Solid Epoxy Mortar (ANSI A118.3)
- GROUT
Flextile Polymer Modified Grout (ANSI A118.7)
ColourMax Plus Urethane Grout
Flexepoxy 100 – 100 % Solid Epoxy Grout (ANSI A118.3)

APPLICATION

- Apply sound reduction membrane following manufacturer's recommendations to provide complete coverage of the substrate in the area on which the tile is to be installed. Install tile in accordance with ANSI A 108.5
Use sufficient bond-coat to ensure a minimum 95% contact.
- All perimeters must be recessed away from the walls and acoustic sealant or prefabricated movement joints must be applied. Slide tile firmly into position while bond coat is wet and tacky. Force grout into full depth of tile joint.
Remove excess grout and clean.

LIMITATIONS

- Some systems may require epoxy grout and/or epoxy bond-coat.
- Some products/systems cannot be used in commercial applications where heavy loads and carts will be used. A "Light Commercial" to "Heavy Commercial" rating utilizing ASTM C-627-99 should be required.

OTHER CONSIDERATIONS

- Sound reduction membranes are intended to minimize the transfer of sound from one room to the room below, it is however only part of the overall system. Substrates, flooring material, dropped ceiling assemblies, perimeter joints, etc, will all affect the overall values.
- Movement Joint (architect must specify type of joint and show location and details on drawings)
- Movement joints - mandatory according to Detail 301MJ-2009/2010.
- All systems must meet or exceed a "Residential Rating" with ASTM C-627-99
- Some systems require 2 layers of 15 mm type X Gypsum Ceiling
- Refer to notes on "Sound Control Underlayment" Boards
- Ratings may vary from **35 IIC to approximately 52 IIC** using ASTM E-492 depending on product and other components in the system.
- This floor assembly has little or no effect on STC rating, normally this floor assembly will have an STC of 50 or more, when the appropriate sound rated wall detail is used.
- Request for test results for ASTM E-2179-03 from manufacturer to determine contribution on a concrete slab.
Product specified should have a contribution (Δ) IIC rating of 20 or greater. A bare concrete slab 152 mm thick with no ceiling panels will have approximately an IIC of 28. Alternatively, a concrete slab 203 mm thick with no ceiling panels will have approximately an IIC of 32.

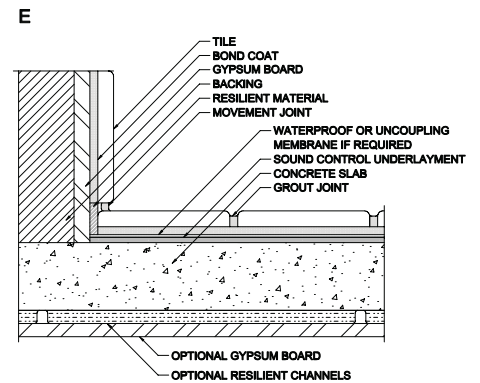

The above installation detail is used with the permission of the Terrazzo Tile & Marble Association of Canada. The installation products shown are Flextile's product recommendations for this specific detail, and are not intended to replace TTMAC's original generic specification.

331F-SC SOUND CONTROL SYSTEMS ON INTERIOR FLOORS

Detail-F THICK SYSTEM ON CONCRETE NO DROPPED CEILING

SUITABLE SUBSTRATES

- Interior concrete slabs. Floor systems over which the tile is installed shall be in conformance with the Canadian National Building Code 2005 and applicable local building codes taking into consideration anticipated live and dead loads.

MATERIALS

- SOUND REDUCTION MEMBRANE
2000SC Flexilastic Sound Control & Crack Isolation Membrane with 4000 or 4001 Flexilastic Primer (ANSI 118.12)
- BOND COAT:
Flextile 50, 52, 56SR, 61, 62 or 66 Polymer Modified Mortars (ANSI A118.4)
Flextile 51 / 44 – two component Latex Mortar System (ANSI A118.4/A118.11)
Flextile 58XT Fast Set two-component Latex Mortar System (ANSI A118.4/A118.11)
Flexepoxy 100 – 100 % Solid Epoxy Mortar (ANSI A118.3).
- GROUT
Flextile Polymer Modified Grout (ANSI A118.7)
ColourMax Plus Urethane Grout
Flexepoxy 100 – 100 % Solid Epoxy Grout (ANSI A118.3).

APPLICATION

- Apply sound reduction membrane following manufacturer's recommendations to provide complete coverage of the substrate in the area on which the tile is to be installed. Install tile in accordance with ANSI A 108.5 Use sufficient bond-coat to ensure a minimum 95% contact.
- All perimeters must be recessed away from the walls and acoustic sealant or prefabricated movement joints must be applied. Slide tile firmly into position while bond coat is wet and tacky. Force grout into full depth of tile joint. Remove excess grout and clean.

LIMITATIONS

- Some products/systems cannot be used in commercial applications where heavy loads and carts will be used. A "Light Commercial" to "Heavy Commercial" rating utilizing ASTM C-627-99 should be required.
- This assembly will normally raise the floor from anywhere from 30 mm to 62.5 mm in height. Height restrictions should be evaluated.

OTHER CONSIDERATIONS

- Sound reduction membranes are intended to minimize the transfer of sound from one room to the room below, it is however only part of the overall system. Substrates, flooring material, dropped ceiling assemblies, perimeter joints, etc, will all affect the overall values.
- Movement Joint (architect must specify type of joint and show location and details on drawings)
- Movement joints - mandatory according to Detail 301MJ- 2009/2010.
- All systems must meet or exceed a "Residential Rating" with ASTM C-627-99
- Some systems require 2 layers of 15 mm type X Gypsum Ceiling
- Refer to notes on "Sound Control Underlayment".
- Ratings may vary from 40 IIC to approximately 60 IIC using ASTM E-492 depending on product and other components in the system.
- This floor assembly has little or no effect on STC rating, normally this floor assembly will have an STC of 50 or more, when the appropriate sound rated wall detail is used
- Request for test results for ASTM E-2179-03 from manufacturer to determine contribution on a concrete slab. Product specified should have a contribution (Δ) IIC rating of 20 or greater. A bare concrete slab 152 mm thick with no ceiling panels will have approximately an IIC of 28. Alternatively, a concrete slab 203 mm thick with no ceiling panels will have approximately an IIC of 32.
- Detail 314F-G Modular Screed System on concrete can be used as alternative to a monolithic mortar bed

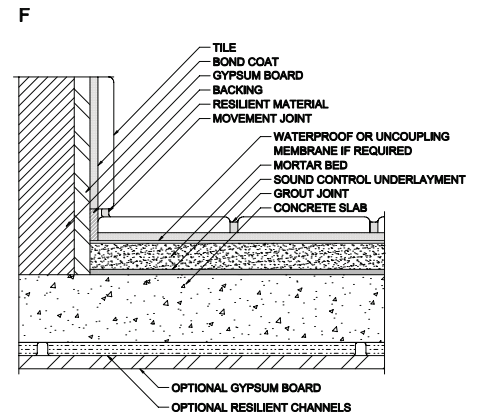

The above installation detail is used with the permission of the Terrazzo Tile & Marble Association of Canada. The installation products shown are Flextile's product recommendations for this specific detail, and are not intended to replace TTMAC's original generic specification.